

★ **Key Point**

Easy clamping and unclamping.  
Handle clicks at clamping end.

Handle	Ring Nut / Washer	Stud
SCM440 steel Quenched and tempered Electroless nickel plated	S45C steel Quenched and tempered Electroless nickel plated	SCM435 steel Quenched and tempered Electroless nickel plated

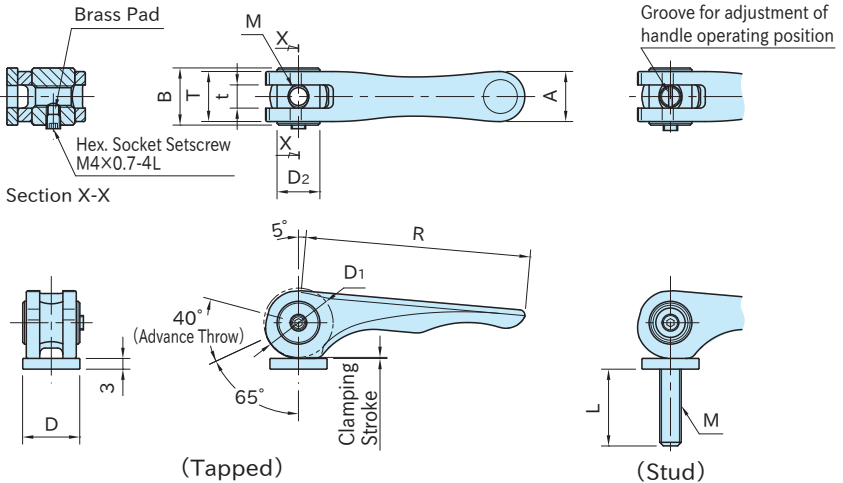

Type		D <sub>1</sub>	R	A	D	M	T	t	B	D <sub>2</sub>	Clamping Stroke
QLCL-NP	06	19.4	63	14	16	M6X1	14	6.5	16	12	0.3
	08	23.2	80	18	20	M8X1.25	18	9	20	15	0.4

Type		Advance Stroke	Allowable Operating Load (N)	Clamping Force (kN)	Clamping Mechanism
QLCL-NP	06	0.8	40	0.7	Spiral Cam Cam Angle : 2°
	08		50	1.4	

## QLCL-NP (Tapped)

Part Number	Weight (g)
QLCL-06-NP	64
QLCL-08-NP	121

## QLCL-NP (Stud)

Part Number	L	Weight (g)
QLCL-06×20-NP	22	72
QLCL-06×30-NP	32	75
QLCL-06×40-NP	42	77
QLCL-06×50-NP	52	79
QLCL-08×25-NP	27	139
QLCL-08×30-NP	32	141
QLCL-08×40-NP	42	145
QLCL-08×50-NP	52	149

### Feature

- By its unique cam design, the handle clicks at clamping end.
- Compared to conventional cam handles, this product has higher resistance against vibration.
- The handle position of Stud-type Cam Handles can be set to a desired direction.

### How To Use

#### Application Example

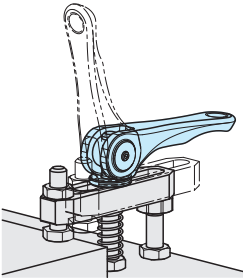

#### Fixing the Cam Handle

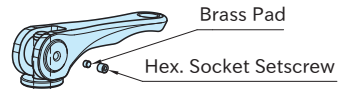

Use a brass pad and a hex. socket setscrew included to fix the handle.

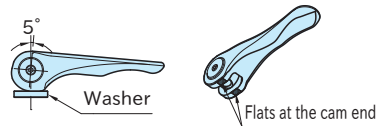

Note: Top surface of washer and flats at the cam end should align at the clamping position.

#### Mounting Stud-type Cam Handles

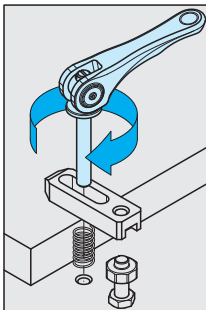

1. Fix the stud to the handle with a brass pad and a hex socket setscrew and screw the Cam Handle to the counterpart.

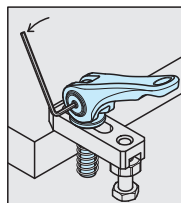

2. Turn the handle to a desired direction and loosen the setscrew.

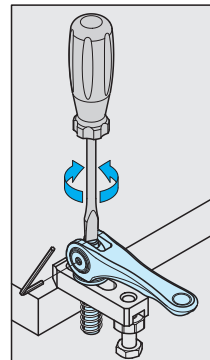

3. With a flathead screwdriver, adjust the handle to a desired clamping height and the load to fold the handle. Then fix the stud with the setscrew.